

SEC No : 4889 WEIGHT Kg/Mtr 2.814

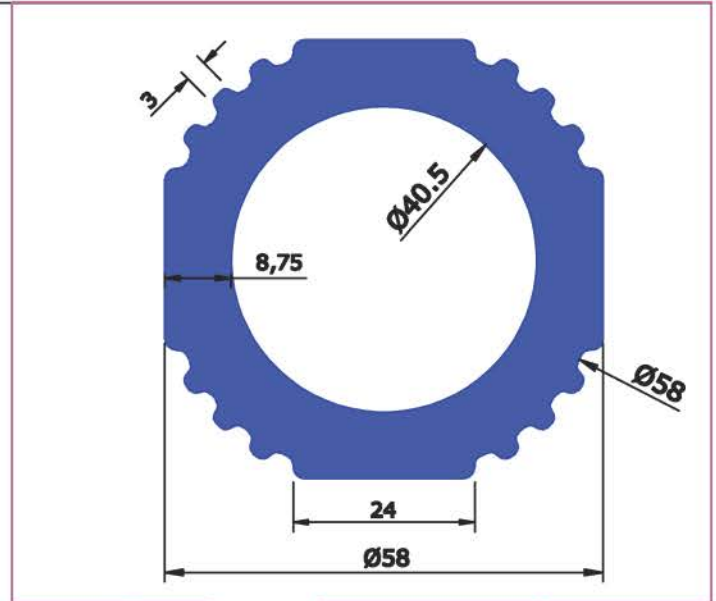

SEC No : 4890 WEIGHT Kg/Mtr 4.057

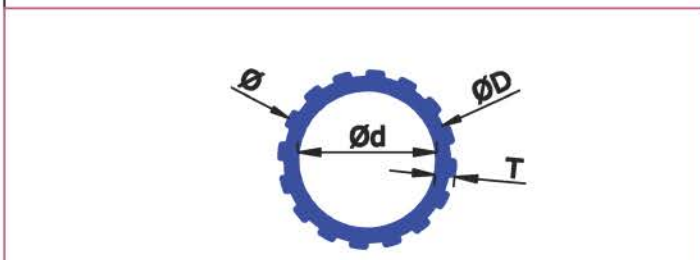

SL No.	SEC No.	Ø	D	d	T	WEIGHT KG/Mtr
1	7463	26.00	24.20	20.40	2.80	0.437
2	1337	50.80	49.00	45.20	2.80	0.928

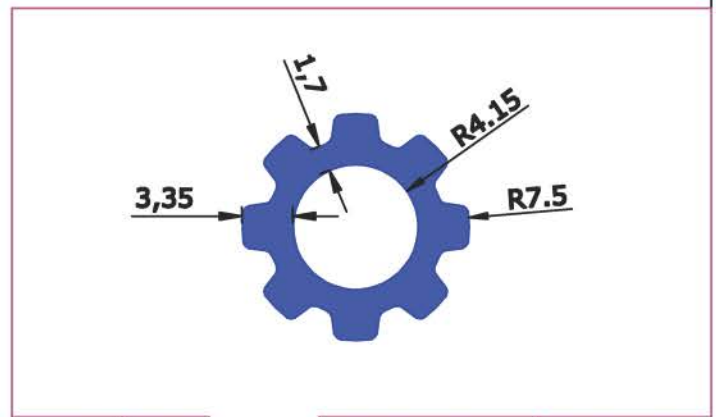

SEC No : 7922 WEIGHT Kg/Mtr 0.245

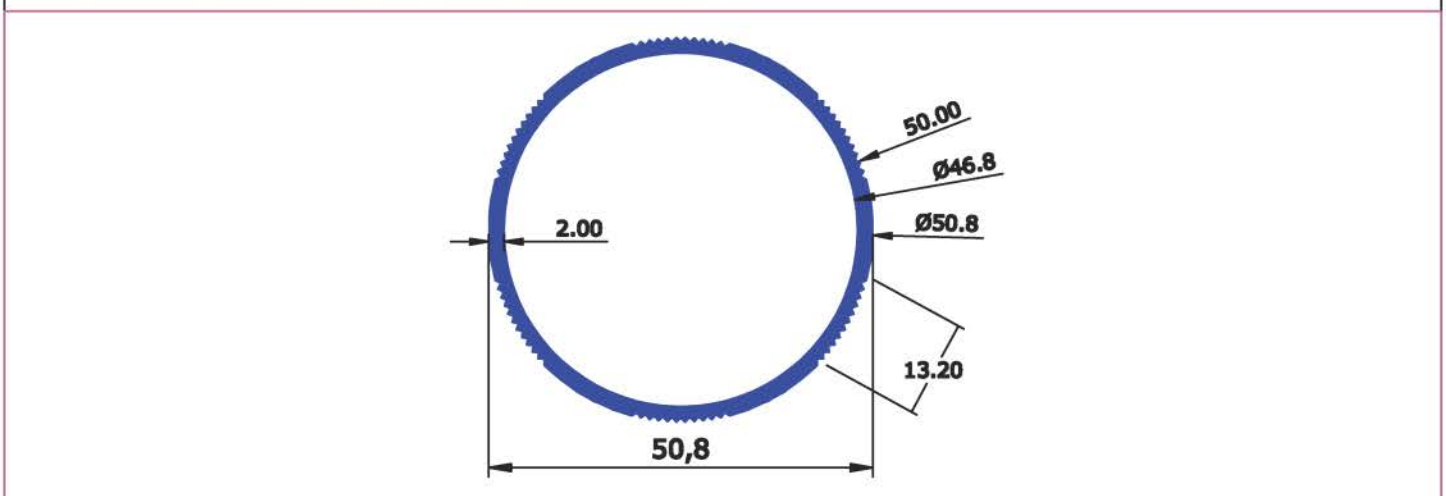

SECTION No : 5028 WEIGHT KG/Mtr 0.737

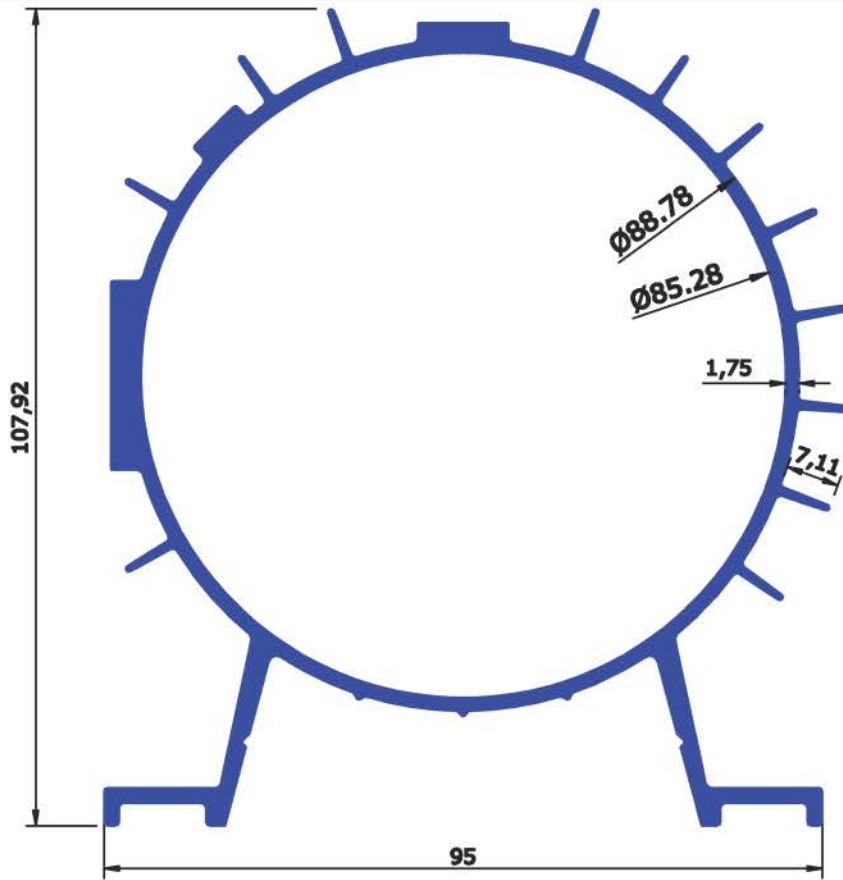

SECTION No : 7110

WEIGHT KG/Mtr

2.363

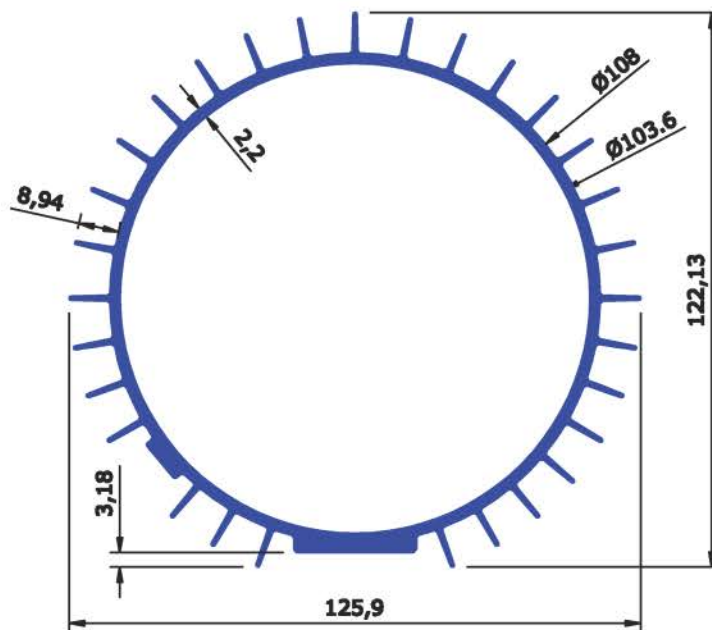

SECTION No : 7138

WEIGHT KG/Mtr

2.937

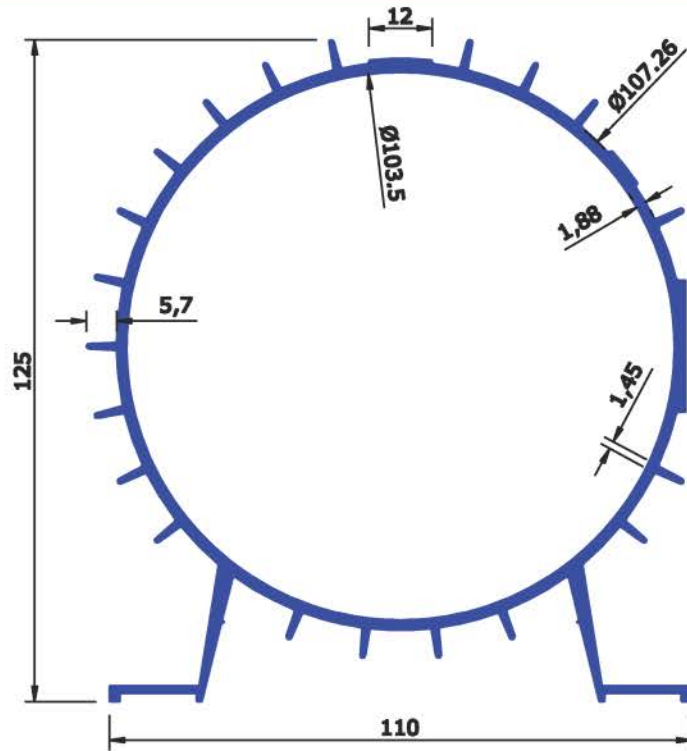

SECTION No : 7145

WEIGHT KG/Mtr

2.568

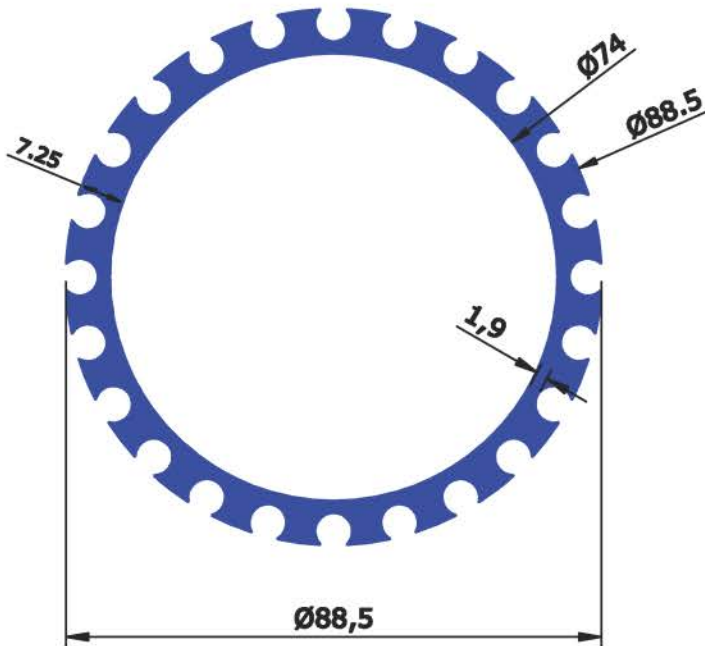

SECTION No : 4546

WEIGHT Kg/Mtr

3.142

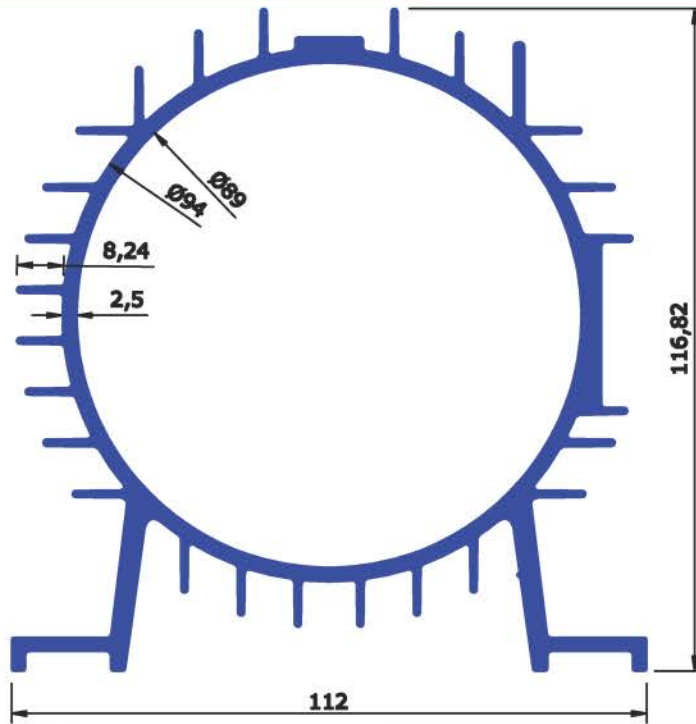

SECTION No :	7148	WEIGHT KG/Mtr	3.866
--------------	------	---------------	-------

REV: 02

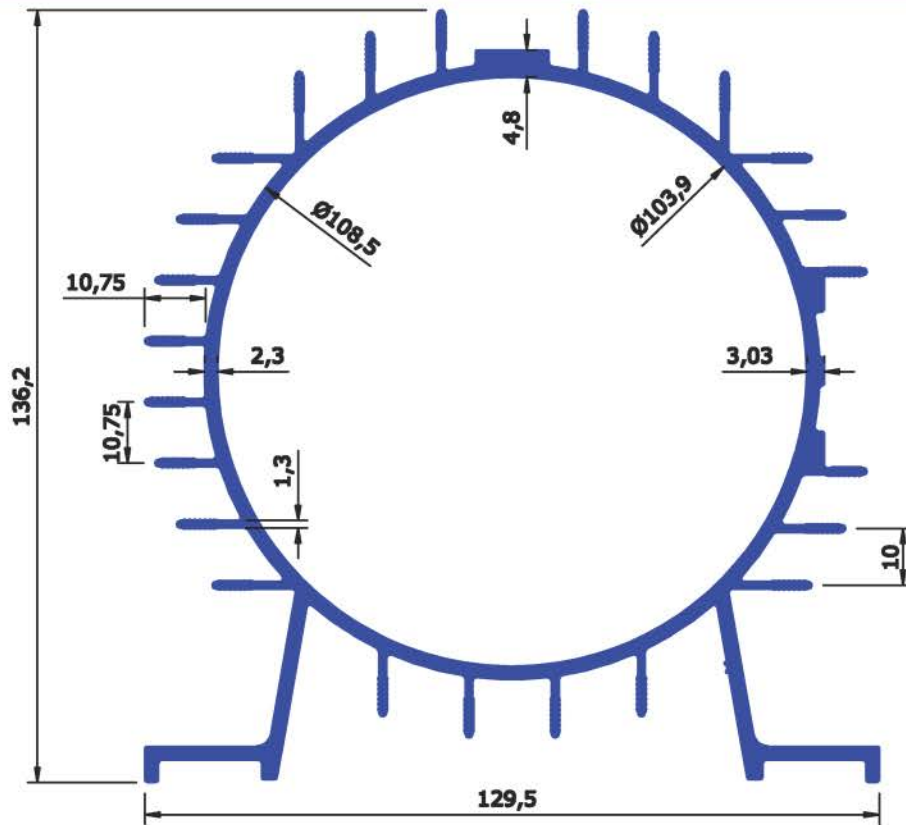

SECTION No :	7149	WEIGHT KG/Mtr	4.126
--------------	------	---------------	-------

Revised drawing

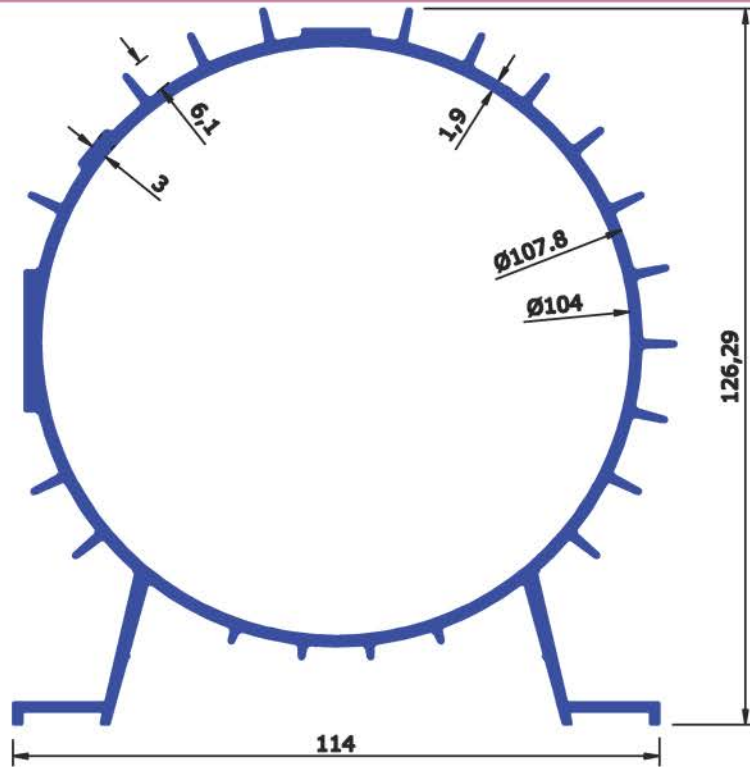

SECTION No : 7146

WEIGHT KG/Mtr

2.704

REV: 01

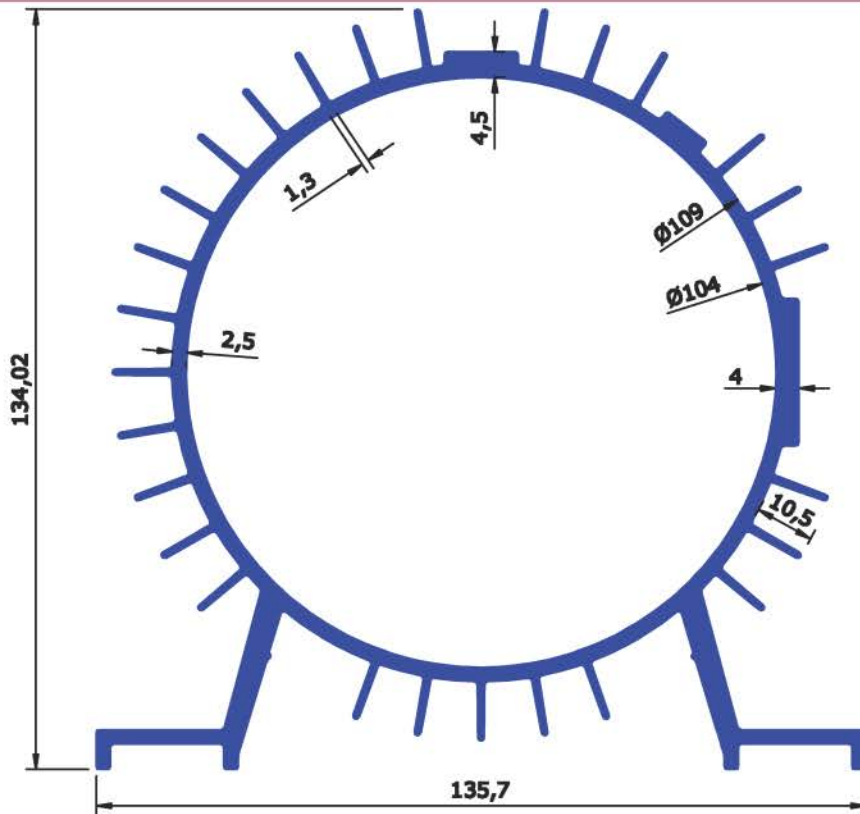

SECTION No : 7147

WEIGHT KG/Mtr

4.444

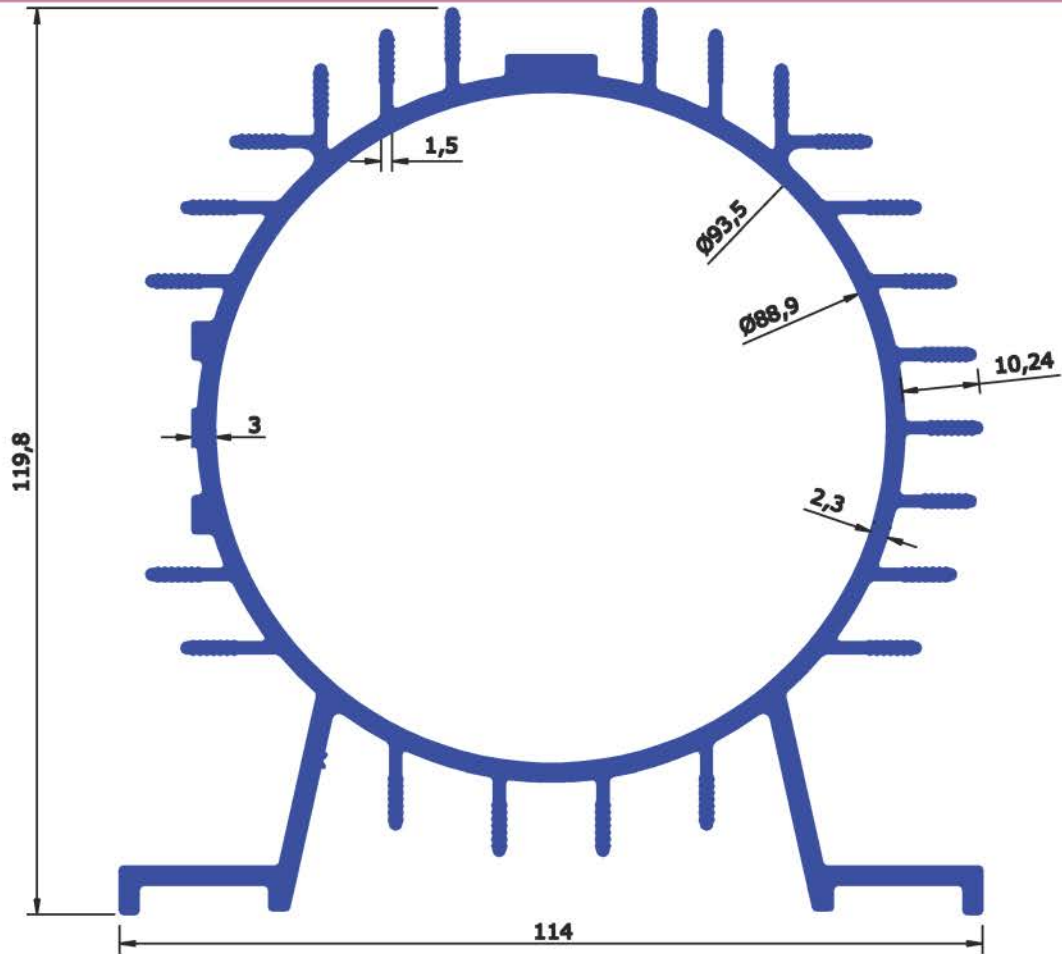

SECTION No :	7139	WEIGHT KG/Mtr	3.783
--------------	------	---------------	-------

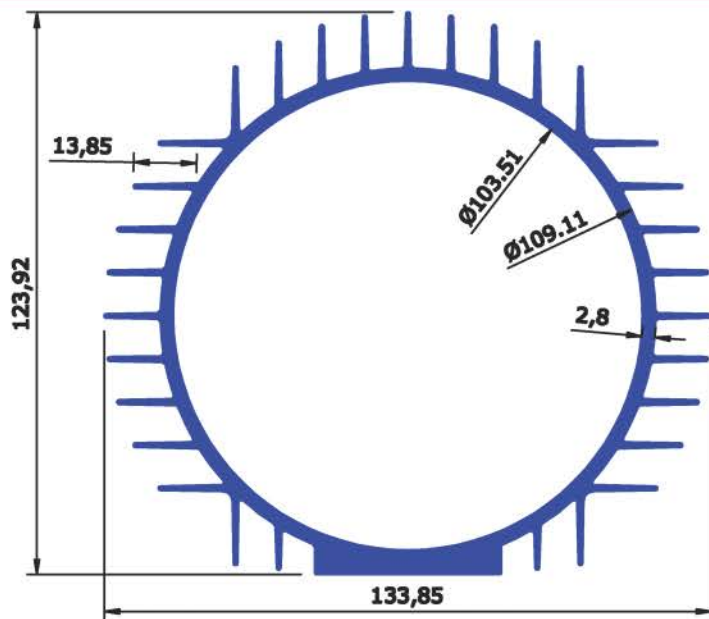

SECTION No :	7140	WEIGHT KG/Mtr	4.357
--------------	------	---------------	-------

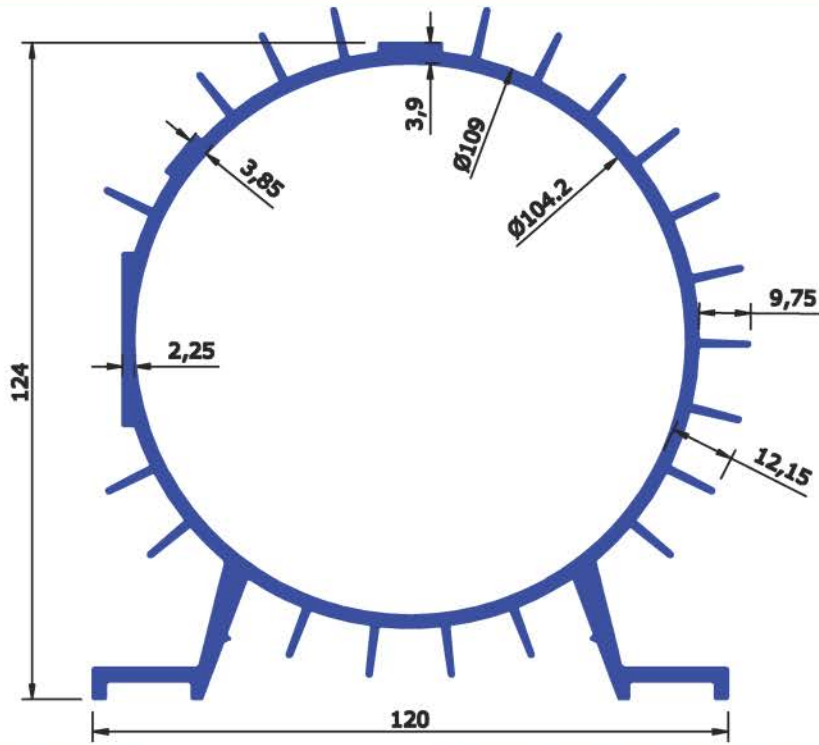

SECTION No :	7141	WEIGHT KG/Mtr	3.762
--------------	------	---------------	-------

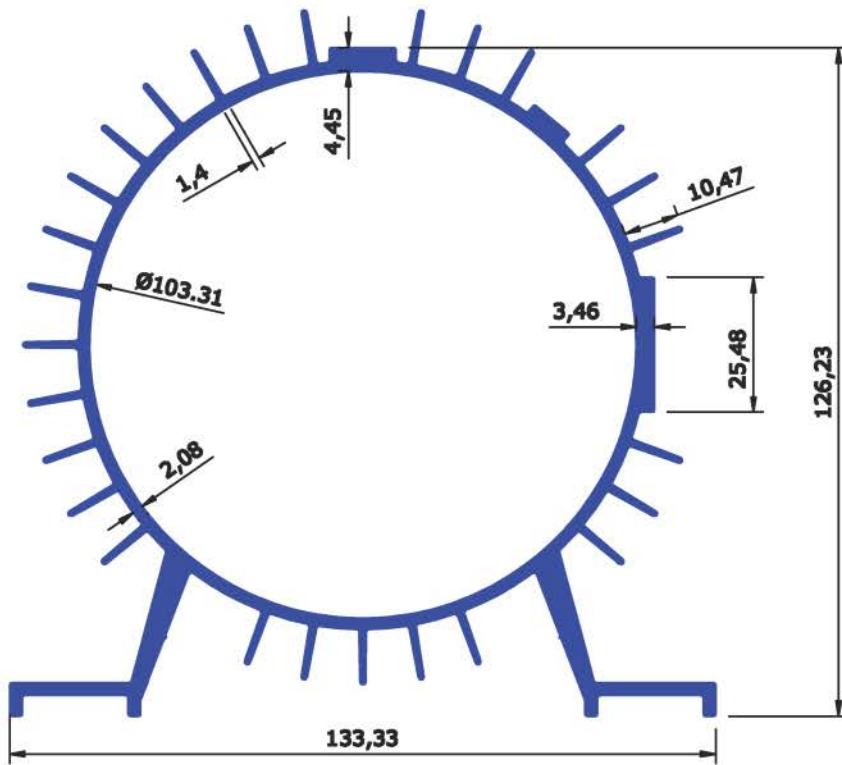

SECTION No :	7142	WEIGHT KG/Mtr	4.038
--------------	------	---------------	-------

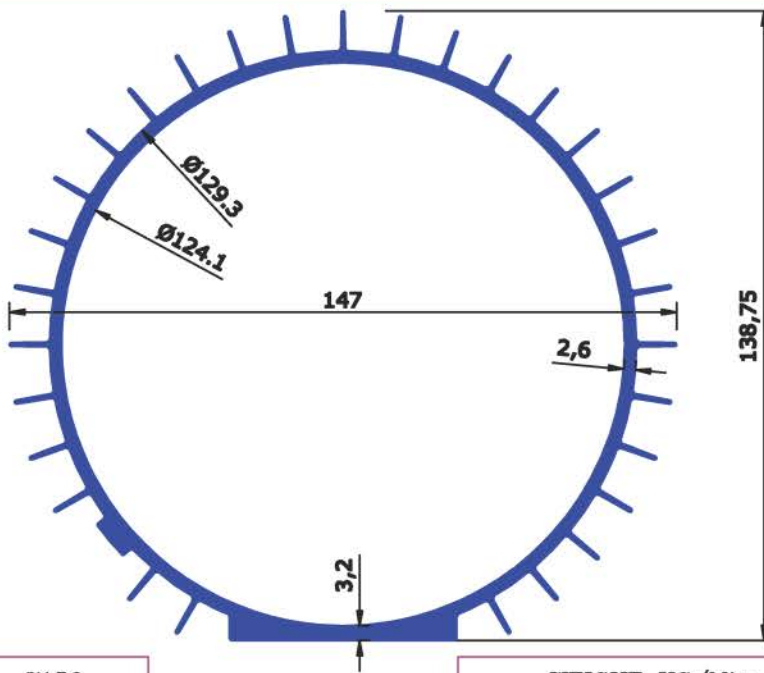

SECTION No	7150	WEIGHT KG/Mtr	3.825
------------	------	---------------	-------

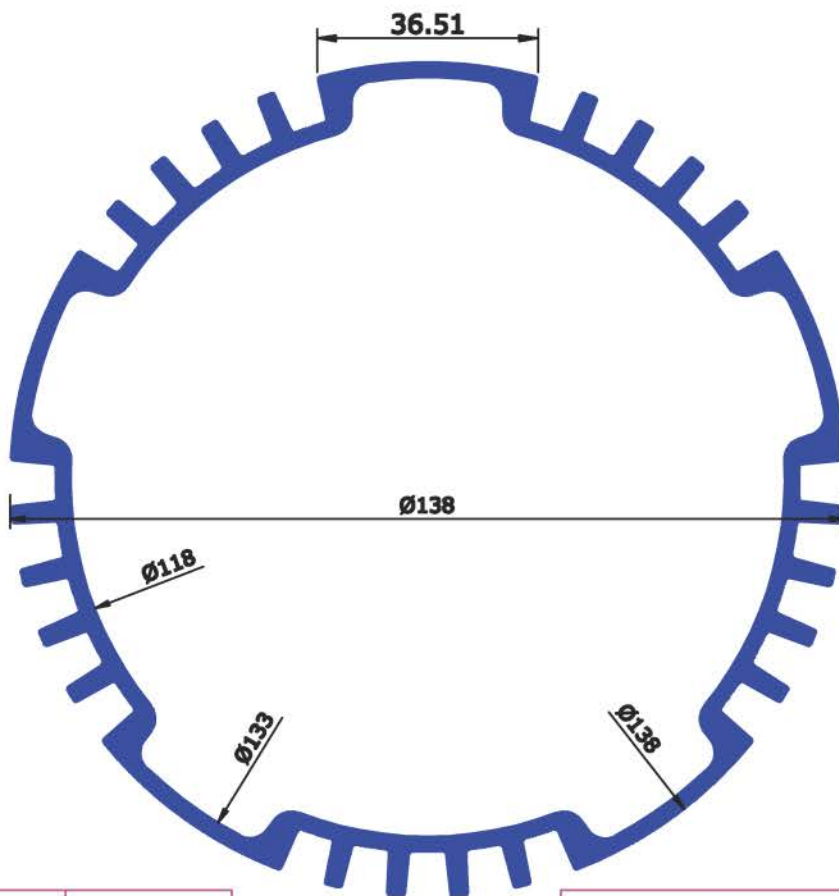

SECTION No :	7010	WEIGHT Kg/Mtr	4.863
--------------	------	---------------	-------